

Leemac

MODEL : FS502 SERIES

SPECIFICATIONS

MOTORS	1
SPEED	3
AIRFLOW	310 m/3h
MOTOR ABSORPTION	120 Watts
LIGHTS HALOGEN SCREW	2 X 40 Watts
NOISE LEVEL	61.5 (dB)
DUCT SIZE	125 mm Dia

- * Stainless Steel & White
- * Aluminium filters (Dishwasher Safe)
- * Twin Halogen screw in Lights
- * 600 mm wide (Stainless & White Single Motor only)

ACCESSORIES

- Carbon Filters F-C 17(1 per Motor)
- EXT TELESCOPIC Duct Cover

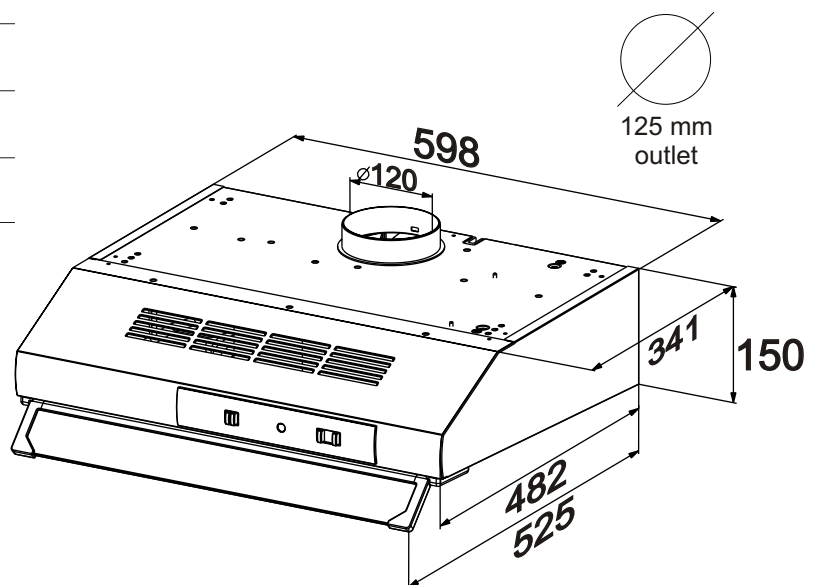

LEEMAC APPLIANCES
 U28 / 14 - 16 STANTON ROAD
 SEVEN HILLS NSW 2147
 AUSTRALIA
 PH - 02 9674 9955
 FAX - 02 9674 9055

Email-pezooffice@leemac.com.au Web-www.leemac.com.au