

# Leemac



## MODEL : CH8B SERIES

### SPECIFICATIONS

SPEED	3
AIRFLOW	970 m <sup>3</sup> /h
MOTOR ABSORPTION	210 Watts
LIGHTS HALOGEN	3 X 20 Watts
NOISE LEVEL	62 (dB)
DUCT SIZE	150 mm Dia

- \* Stainless Steel
- \* Baffle filters (Dishwasher Safe)
- \* Triple Halogen Lights
- \* Drop out Motor System
- \* 900 mm wide only



### ACCESSORIES

- Carbon Filters F-C 16
- EXT Flue for 10' ceilings

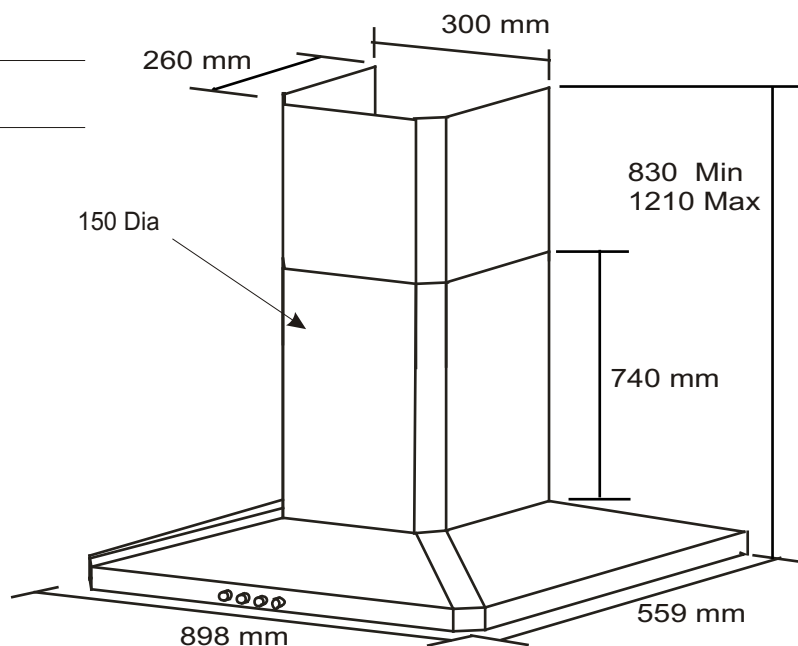

PH - 02 9674 9955  
FAX - 02 9674 9055  
Email-pezoffice@leemac.com.au Web-www.leemac.com.au

LEEMAC APPLIANCES  
U28 / 14 - 16 STANTON ROAD  
SEVEN HILLS NSW 2147  
AUSTRALIA